

# Synchronous Low Voltage High Performance Single Port Static Memory Compiler – FSA0A\_L\_SR

## Key Features

- Operating voltage range: 1.2V ~ 1.8V
- Operating junction temp. range: -40°C ~ 125°C
- Recommended operating ambient temp. range: 0°C ~ 85°C
- Synchronous read and write operations
- Fully customized layout density
- Minimum metal requirement: 4 metal layers
- Automatic power down mechanism to eliminate DC current
- Clocked address inputs and CS to RAM at CK rising edge
- Clocked WEB input pins to RAM at CK rising edge
- Clocked DI input pins to RAM at CK rising edge
- Byte write and word write operations available
- Verilog / VHDL timing / simulation model generator
- SPICE netlist generator
- GDSII layout database
- Memory compiler preview UI (Memaker)
- BIST circuitry supported
- Column mux options for the best aspect ratio

## General Description

The FSA0A\_L\_SR is a low voltage, synchronous, high performance, single port memory compiler. It is implemented according to UMC's 0.18µm logic process design rules. Different combinations of words, bits, and aspect ratios to be used for generating the most desirable configurations.

By requesting the desirable size and timing constraints, the FSA0A\_L\_SR compiler is capable of providing suitable synchronous SRAM layout instances in minutes. It automatically generates data sheets, Verilog / VHDL behavioral simulation models, SCS or Viewlogic symbols, place & route models, and test patterns for use in ASIC designs. The duty cycle length can be neglected as long as the setup / hold time and minimum high / low pulse widths are satisfied. This allows the flexibility of a clock falling edge during each operation. Both word write and byte write operations are supported.

## Symbol

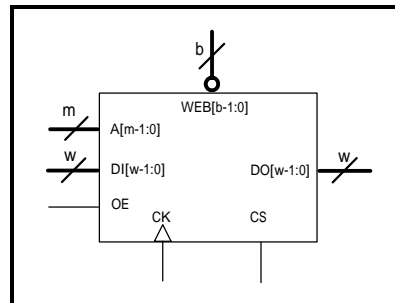

## Quick Reference

Maximum Capacity	72K bits
Maximum Words	4K
Minimum Words	8
Maximum Bits	72
Minimum Bits	1
Bit Increment	1
Aspect Ratio (Column Mux)	4, 8, 16

### HEADQUARTERS

Hsinchu, Taiwan,  
 Tel: 886-3-578-7888  
 Fax: 886-3-578-7889  
 sales@faraday.com.tw

### USA OFFICE

Sunnyvale, USA  
 Tel: 1-408-522-8888  
 Fax: 1-408-522-8889  
 sales@faraday-usa.com

### EUROPE OFFICE

Hoofddorp, Netherlands  
 Tel: 31-2356-20496  
 Fax: 31-2356-36297  
 eusales@faraday.com.tw

### JAPAN OFFICE

Tokyo, Japan  
 Tel: 81-3-5214-0070  
 Fax: 81-3-5214-0076  
 sales@faraday.co.jp

### CHINA OFFICE

Shanghai, P. R. China  
 Tel: 86-21-6406-7523  
 Fax: 86-21-6406-5327  
 sales@faraday.com.cn